



Multi-Cleaner 520ltr.



Multi-Dumper elektro



Seat with spring borne and foot service brake



Rotary Sweeper



Light cargo tray 450ltr.



Snow plough

MCE100



Technical Data

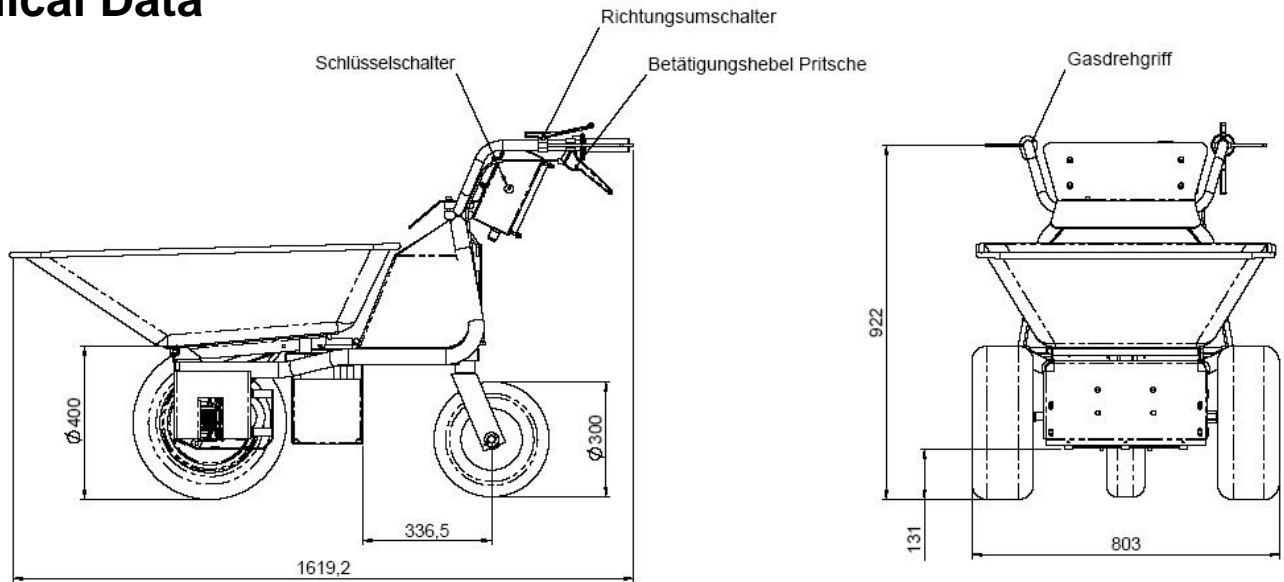

Drive	electric
Electric tension	24V
Power	1000 W
Climbing ability	max. 40 %
Revolutions per minute	2200 RPM

Operational specs.	
Weight	130 kg
Max. Payload	350 kg
Capacity	110 Liter (standard)
Dumping device	mechanical / pneumatically backed
Operating time	8 – 10 h
Working speed	0 – 6 Km/h forward, progressively adjustable 0 – 3 Km/h backward, progressively adjustable

Series fabrication type

2 Accumulator batteries à 12V / 80Ah
 Battery charger
 Field tyres 16x6.50-8
 Differential Gear

Optional extensions

Rotary Sweeper 85cm incl. collector 60ltr.
 Rotary Sweeper 105cm adjustable
 Snow plough 85cm incl. Special rubber strip
 Snow chains
 Transport box (900 x 790 x 260mm)
 Multi-Cleaner 520ltr.
 Light cargo tray 450ltr. (1160 x 905 x 565mm)
 Watertank 200ltr.
 Feed wagon
 Seat with spring borne and foot service brake

Authorised dealer:



Baumaschinen GmbH

Niederhöchstädter Str. 71-73 D-61476 Kronberg
 Tel.: 0049-(0)6173-68558 Fax: 0049-(0)6173-68548
 E-Mail: info@powerpac.de Internet: www.powerpac.de