



Multi-Loader



optional with wheels

ML 350



Multi-Loader ML 350

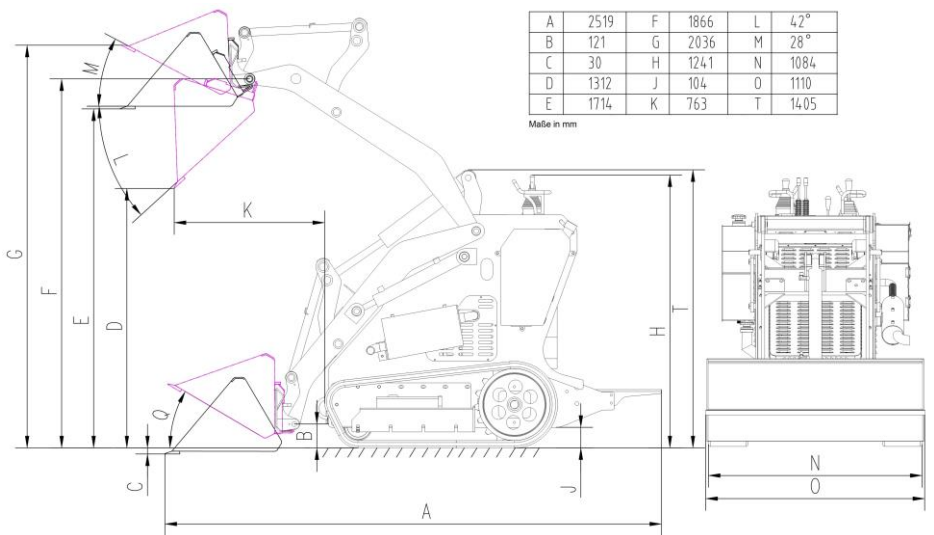
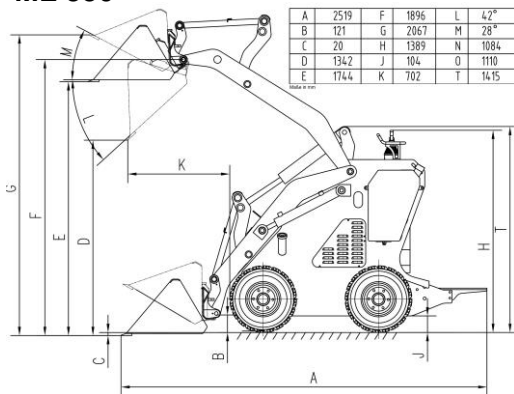

Technical Details

Motor	
Honda	GX 690
Type	2 Zyl. / 4-stroke
Displacement	688 cm ³
Engine output	18,4 kW (25,0 HP)
Revolution speed	3600rpm
Starter	electric starter
Air filter	dry cell
Fuel filter	gauze



drive	hydrostatic
Guidance	hydraulic motor Eaton USA
Multi-valve block	Hydrocontrol Italy
hydraulic pump	Permco USA
Characteristic	quick-change system joystick control, electric start



operating data	
weight	
without accessory	850 kg
Max. payload	350 kg
Max. operating weight (loaded)	1200 kg
tipping device	hydraulic
climbing ability	max. 20° (36%)
working speed	0 – 5 km/h
oil pressure	180 bar
flow rate oil pump	24.6 ltr./min.



accessory	4 in 1 bucket, attachment excavators, pallet fork, gripper, auger, sweeper
------------------	--



Baumaschinen GmbH

Niederhöchstädter Str. 71-73 D-61476 Kronberg
Tel.: 0049-(0)6173-68558 Fax: 0049-(0)6173-68548
E-Mail: info@powerpac.de Internet: www.powerpac.de