



Track-Dumper



RD 370



Track-Dumper RD 370

Technical Data

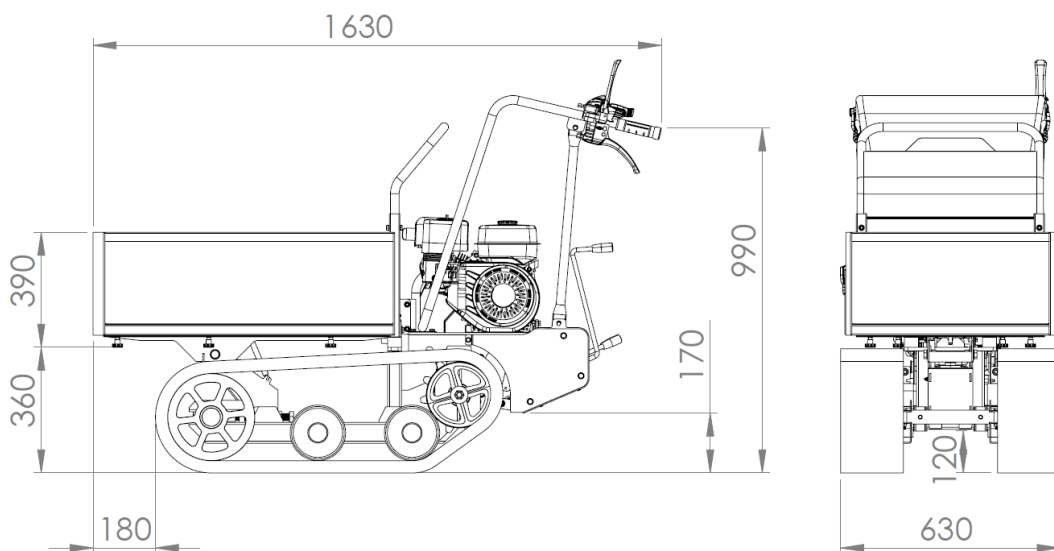

Engine	
Honda	GX 160
type	1 cyl. / 4-stroke
displacement	163 cm ³
engine output	4,1 kW (5,5 HP)
revolution speed	3600/rpm
starter	reversing starter
air filter	dry cell
fuel filter	gauze



drive	toothed gearing
brake	steering clutch
adjustable load carrying side walls	length variable 820 - 1000 mm width variable 540 - 1000 mm height standard side walls 300 mm + height increased side walls 300 mm
characteristic	the loading area can be increased by pulling out the load carrying walls. load carrying walls can be complete pull out.



operating data	
weight	170 kg
max. payload	370 kg
max. weight (loaded)	540 kg
tipping device	mechanical
climbing ability	max. 26° (50%)
working speed 6+2	0,50 - 1,30 km/h gear 1-3 forward 1,80 - 4,90 km/h gear 4-6 forward 0,60 - 2,30 km/h gear 1-2 reverse
platform volume	160 ltr.



Baumaschinen GmbH

Niederhöchstädter Str. 71-73 D-61476 Kronberg
Tel.: 0049-(0)6173-68558 Fax: 0049-(0)6173-68548
E-Mail: info@powerpac.de Internet: www.powerpac.de