



Vibratory plates

reversible

PPR 2100 B
PPR 2100 D



Technical data

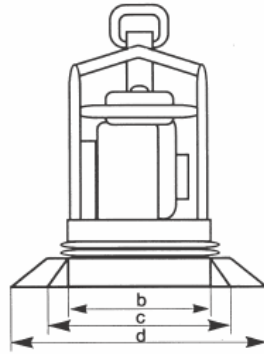
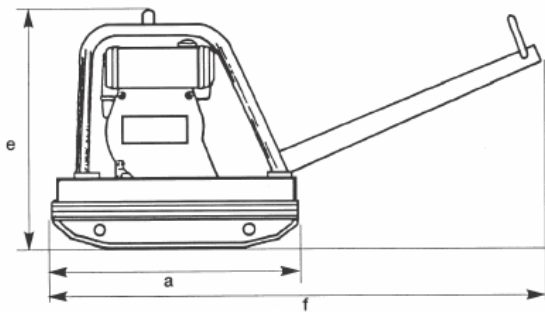

optional accessory:
wheel set + rubber plate

Type	a (length)	b (width)	Height 1 handle opened	Height 2 handle closed
PPR 2100 B	632	400	640	1200
PPR 2100 D	632	400	700	1200

Type	PPR 2100 B	PPR 2100 D
Engine	Honda	Hatz
Constructor	GX 160	1 B 20
Model	1-cyl. / 4 - stroke petrol	1-cyl. / 4 - stroke diesel
Type	160 cm ³	232 cm ³
Displacement	4,04 kW (5,5 HP)	3,4 kW (4,6 HP)
Engine output	3600	3600
RPM	reversing starter	reversing starter
Starter	dry cell	dry cell
Air filter	gauze	filter element
Fuel filter		

Exciter drive	centrifugal clutch and v belt
----------------------	-------------------------------

Exciter	2- shaft exciter - continuously variable
----------------	--

Operational characteristics	PPR 2100 B	PPR 2100 D
Weight	95 kg	120 kg
Centrifugal force	21 kN	21 kN
Footprint	2528 cm ²	2528 cm ²
Centrifugal force / Footprint	7,2 N/cm ²	7,2 N/cm ²
Exciter frequency	90 Hz	90 Hz
Compaction depth*	35 cm	35 cm
Working speed*	0 - 23 m/min	0 - 23 m/min

*depending on soil

Authorised dealer:



Baumaschinen GmbH
 Niederhöchstädter Str. 71-73 D-61476 Kronberg
 Tel.: +49-(0)6173-68558 Fax: +49-(0)6173-68548
 E-Mail: info@powerpac.de Internet: www.powerpac.de